

Automatic Stainless Steel Washbasin Taps with Central Soap Dispenser SLU 45M2 - M6



SLU 45M

Characteristics



- economical aerator, rate of flow 6 l/min
- hygienic flush
- easy soap refilling
- soap economy
- SLU 45M2 - M6 are destined for cold or premixed water
- system reacts to the hands in front of the sensor
- 2 - 6 pcs. of taps with soap dispenser with central unit
- use in the public sector, container for soap 6 l
- parameters adjustment using by the remote control SLD 03

Course graph:

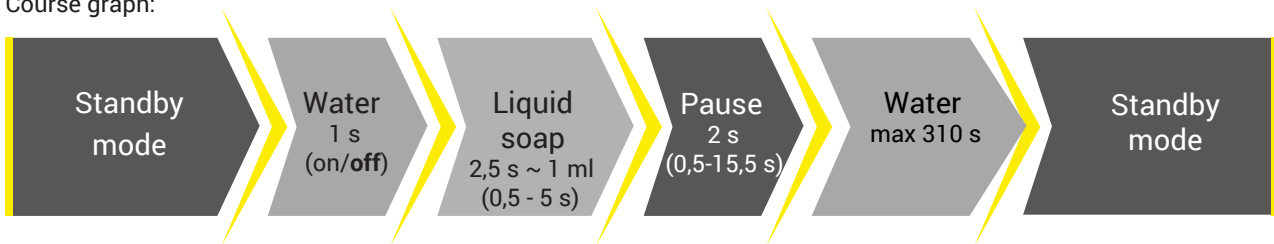

Installation Drawing

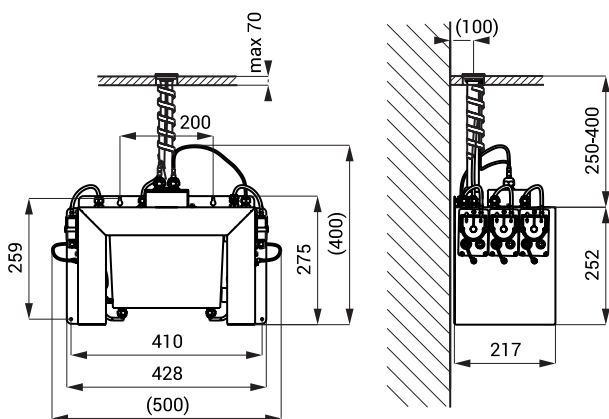
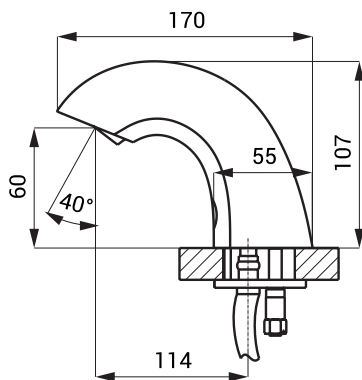

Technical Specification

Operating voltage	
SLU 45M2 - M6	230 V AC
Power input	
SLU 45M2	15 W
SLU 45M3	22 W
SLU 45M4	30 W
SLU 45M5	37 W
SLU 45M6	44 W
Active range	0,14 - 0,2 m
Recommended flow pressure	0,1 - 0,6 MPa
Rate of flow	6 l/min. (inf. data)
Water inlet	male thread G 1/2"
Recommended soap viscosity	10 mPa*s - 5000 mPa*s

(don't use chemical solvents and disinfection)

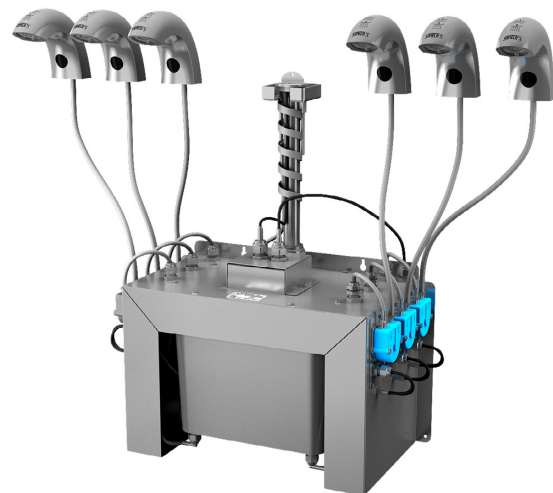

Automatic Washbasin Taps

Supply Specification

SLU 45M2 – Supply No. 03453	faucet with an electronics (2 pcs.), connecting hoses, angle valve with filter (2 pcs.), electromagnetic valve (2 pcs.), central soap dispenser with peristaltic pumps for liquid soap and soap container 6 l, power supply SLZ 01Y, remote control SLD 03
SLU 45M3 – Supply No. 03454	faucet with an electronics (3 pcs.), connecting hoses, angle valve with filter (3 pcs.), electromagnetic valve (3 pcs.), central soap dispenser with peristaltic pumps for liquid soap and soap container 6 l, power supply SLZ 01Y, remote control SLD 03
SLU 45M4 – Supply No. 03456	faucet with an electronics (4 pcs.), connecting hoses, angle valve with filter (4 pcs.), electromagnetic valve (4 pcs.), central soap dispenser with peristaltic pumps for liquid soap and soap container 6 l, power supply SLZ 01Y, remote control SLD 03
SLU 45M5 – Supply No. 03457	faucet with an electronics (5 pcs.), connecting hoses, angle valve with filter (5 pcs.), electromagnetic valve (5 pcs.), central soap dispenser with peristaltic pumps for liquid soap and soap container 6 l, power supply SLZ 01Z, remote control SLD 03
SLU 45M6 – Supply No. 03458	faucet with an electronics (6 pcs.), connecting hoses, angle valve with filter (6 pcs.), electromagnetic valve (6 pcs.), central soap dispenser with peristaltic pumps for liquid soap and soap container 6 l, power supply SLZ 01Z, remote control SLD 03

Recommended Accessories

SLT 04 – Supply No. 09040	thermostatic valve 3/4", rate of flow 28 l/min by the pressure 0,1 MPa
SLT 05 – Supply No. 09050	thermostatic valve 1/2", rate of flow 42 l/min by the pressure 0,1 MPa
SLA 56A – Supply No. 06560	economical aerator 3,8 l/min
SLA 56B – Supply No. 06561	economical aerator 1,9 l/min